

The Multi-Mount Proximity Reader is the first of its kind to offer the flexibility of both mullion and wall mounting in a single cost-effective proximity reader solution. The reader mounts on a standard door mullion but also ships with an attractive adapter plate that allows mounting on a single-gang electrical box.

This reader assures compatibility with electronic access control and time & attendance systems by using an industry standard Wiegand interface. It is compatible with HID proximity credentials for seamless replacement or add-ons to existing sites.

The Multi-Mount Proximity Reader is the perfect choice for dealers and distributors wishing to stock a single, multi-mount proximity reader.



## Features

- Up to 5" Read Range
- Comes with Wall Adapter Plate
- LED and Beeper
- HID Compatible
- Mullion or Wall Mount
- Sleek and Attractive Design
- Wiegand Output

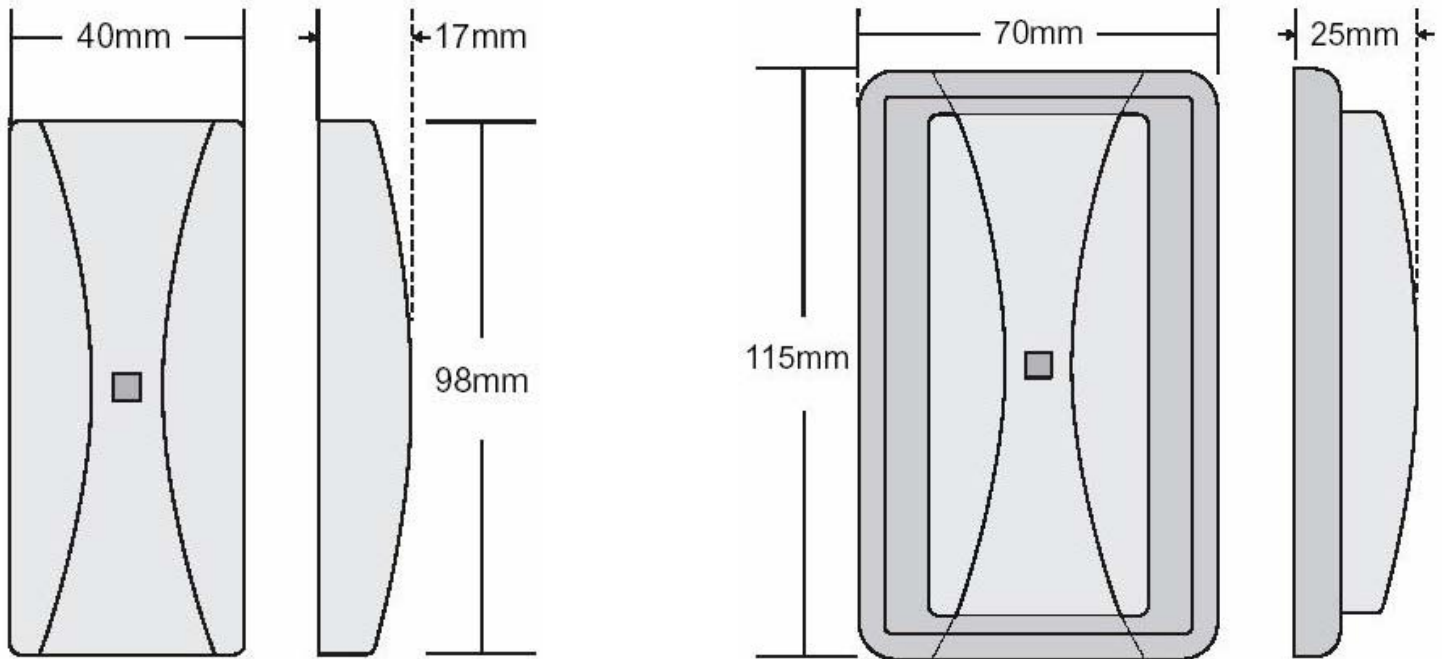

## Specifications

- Read Range:  
Clamshell Card: up to 5" (152 mm)  
Graphic Card: up to 4" (101 mm)  
Keytag: up to 3" (76 mm)
- Frequency: 125 kHz
- Voltage Requirements: +5 to 14VDC
- Current Draw: 45 mA typical, 80 mA peak
- LED: tri-colour, externally controlled
- Beeper standard, externally controlled
- Size: 3.2"(w) x 1.2"(h) x 0.7"(d)
- Weight: 3 oz (85 g)
- Colour: Black
- Mounting: mullion or wall (with adapter)
- Housing: high impact ABS
- Operating Temp.: -40°C to +65°C
- Environment: Indoor or Outdoor
- Wiegand, Six conductor, 22AWG, stranded, overall shield
- Certifications: CE, CSA, FCC

**Warranty:** Lifetime warranty against defects in material and workmanship when installed according to Thomas Access Control Systems installation instructions. See complete warranty statement for further details.

**Disclaimer:** Specifications subject to change without notice. Thomas Access Control Systems reserves the right to make changes to improve performance without impacting form, fit or function.